

FIGURE 1

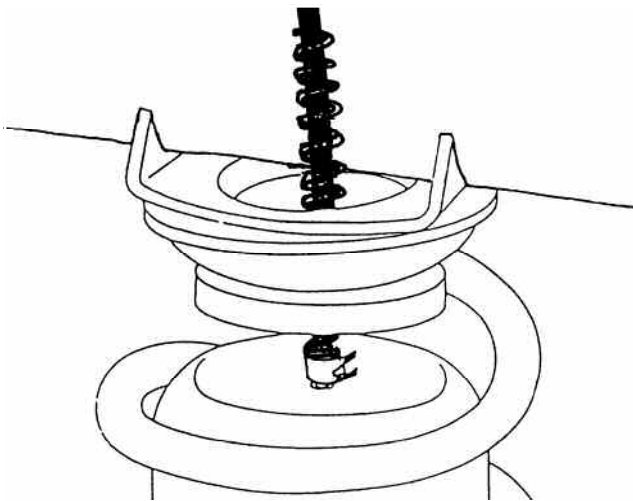



FIGURE 2

Option 1 
 Option 2 

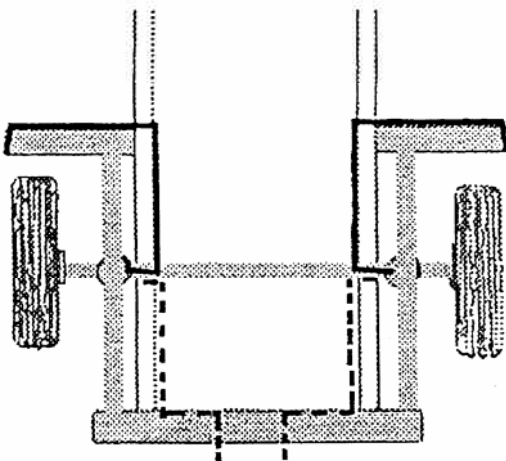

FIGURE 3

1. Before working on vehicle, ensure vehicle is located on safety stands and is secure.
2. Lower axle or raise body of vehicle until suspension is fully extended.
3. Coil springs must be removed from vehicle. Refer workshop manual if uncertain of method. Generally, lower shock absorber mounts and maybe panhard rod must be disconnected.

CAUTION:
OBSERVE TENSION ON BRAKE HOSE
- DO NOT STRAIN -

4. Remove bounce rubbers, from inside coil springs. (Their function will be replaced by the Polyair Kit). Do not remove bounce rubbers fitted under chassis rail.
5. **Drill 44mm (1 3/4") hole in centre of upper spring seat, and deburr. The hole is to accommodate off centre movement of air hose during extended wheel travel.**
6. Select a location for the inflation valves in the rocker sills or rear floor pan ensuring that each valve will be protected and accessible with an air hose. (Figure 3).
7. Determine hose routing and cut adequate length of tube.

CAUTION:
LEAVE SUFFICIENT HOSE SLACK TO PREVENT ANY STRAIN ON VALVE STEM DURING NORMAL AXLE MOTIONS.

8. Attach air hose to bag (Refer A, B, C Overleaf) and thread airline through centre of spacer (if supplied).
9. Insert small coil over airline until it reaches bag nubbin. Secure with insulation tape if desired. Repeat this process for the other side. (Figure 2).
10. Push air bag into coil with hose / stem at top of coil.
11. Thread hose through hole in top spring seat then re-install coil. (Figure 2).

- A. Slide metal hose clamp onto cut tubing.
- B. Push the tube onto the stem, covering all the barbs.
- C. Slide the metal hose clamp forward until it fully covers barbed section.
Repeat process for right side.
- D. Drill 5/16" (8.0mm) hole for inflation valves and mount as illustrated. (Rubber washer for outside weather seal.)
Route tubing along frame to inflation valve location and cut off excess. Secure with plastic straps.
- E. Slide metal hose clamp onto tubing and push tubing onto the fitting, covering all the barbs.
- F. Slide the metal hose clamp forward until it fully covers the barbed section.

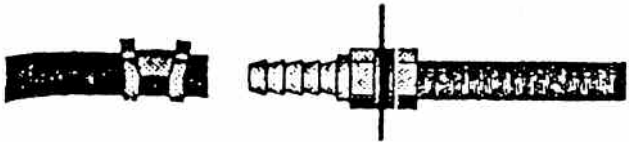
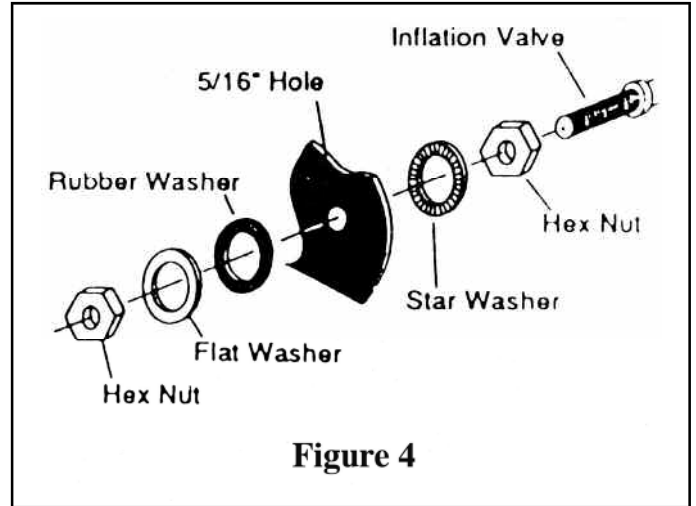

DO NOT INFLATE AIR CYLINDERS BEFORE READING INFLATION PROCEDURES.

- G. Raise axle or lower body until air cylinders lightly touch upper and lower spring seats.
- H. Check TAIL PIPE clearance and ensure that it is as least 3-4 inches (75-100 mm) from air cylinders. If necessary, loosen clamps and rotate or move to obtain additional clearance.
- I. Inflate cylinders to 25lbs. (170kpa) air pressure.
- J. Test for air leaks by applying a liquid soap solution to all valve cores, fittings and connections.
- K. Deflate Polyair Springs to determine best ride and handling. Sufficient air pressure must be maintained to help prevent bottoming-out.

AN ABSOLUTE MINIMUM OF 5 psi MUST BE KEPT AT ALL TIMES.

**CAUTION:
DO NOT EXCEED VEHICLE
MANUFACTURER'S GROSS
VEHICLE WEIGHT RATING.**

INITIAL INFLATION PROCEDURES

*** CAUTION •**

INFLATE BEFORE LOADING

TO OPERATE THE AIR SPRING UNITS, INFLATE THE CYLINDERS TO THE PRESSURE INDICATED BELOW.
LOAD THE VEHICLE THEN DECREASE THE PRESSURE UNTIL THE VEHICLE IS LEVEL DO NOT ATTEMPT TO RAISE A LOADED VEHICLE BY INFLATING THE AIR SPRINGS IF LOADED.
"JACK" UP BODY OF VEHICLE UNTIL LEVEL. AND THEN INFLATE TO THE DESIRED PRESSURE.

MINIMUM	MAXIMUM
PRESSURE	PRESSURE
5 p.s.i.	30 p.s.i.

MAINTENANCE TIPS: Always maintain at least 5 lbs (38 kpa) air pressure in the Air Springs to prevent chafing. When loading it is good practice to increase the inflation pressure of the tyres in proportion to the load being carried.

THIS PAGE FOR 200 SERIES ONLY WITH KDSS SYSTEM

Please note when fitting Polyair Springs to Toyota Landcruiser 200 Series fitted with Toyota's Kinetic Dynamic Suspension System (KDSS), also referred to by Toyota as a "hydro-mechanical semi active anti roll bar"

Please be advised of the fitting procedure:

1. Suspend vehicle on 2-post type chassis hoist allowing wheels to hang.
2. Locate the KDSS valve housing.

NOTE: The valve housing is located on the left-hand side of the vehicle, on the inside of the chassis rail, roughly half way between the front and the back of the vehicle.

3. Using a 5mm hex key, open the 2 leveling valves 3 full rotations anti-clockwise. (Access is from underside of the KDSS valve)

NOTE: The KDSS system is now open and the sway bar ends should be able to be freely manipulated with little effort, allowing spring / strut removal and installation.

NOTE: THE VEHICLE MUST NOT BE DRIVEN WITH THESE VALVES OPEN AS THIS WILL COMPROMISE THE SYSTEM AND RENDER THE VEHICLE UNSAFE TO DRIVE.

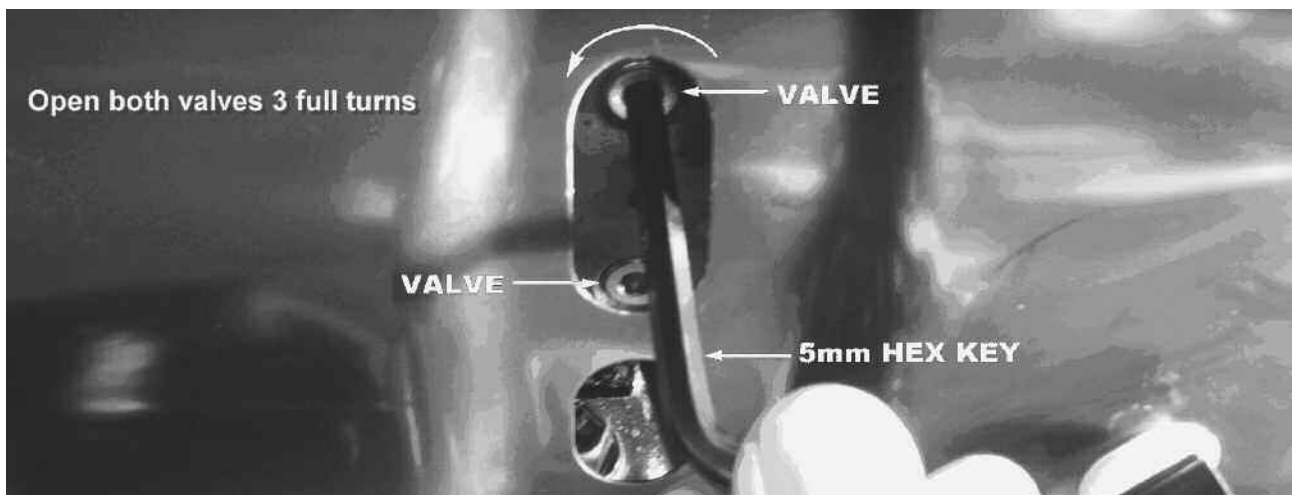

4. With the vehicle sitting on level ground, close both KDSS leveling valves by turning them in a clockwise direction and then tightening.

THIS PAGE FOR 200 SERIES ONLY

Remove spring to release
bounce rubber assembly

Cut rubber cone as shown
Ensure top rubber remains

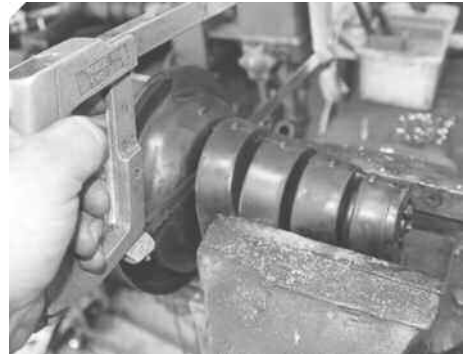

Cut 44mm hole to centre as shown

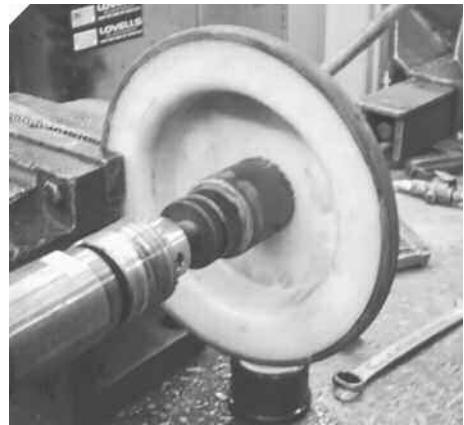

Install to vehicle as shown:

Drilled top assembly

Airline

Coil Spring

Airline protector

Protector Disc

