

FIGURE 1

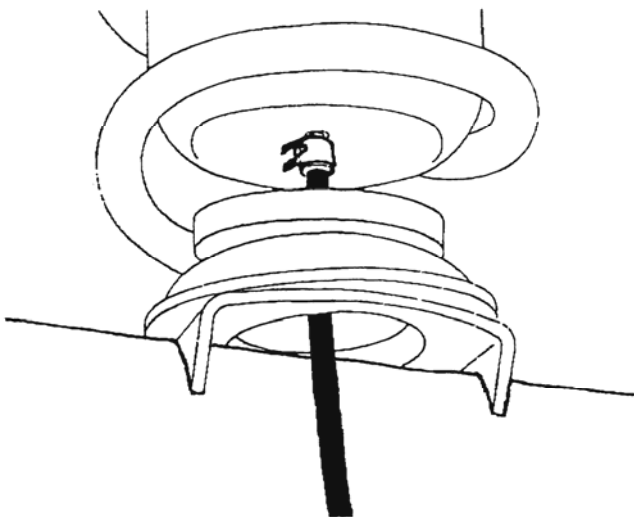

FIGURE 2

Option 1    ———  
 Option 2    ·····

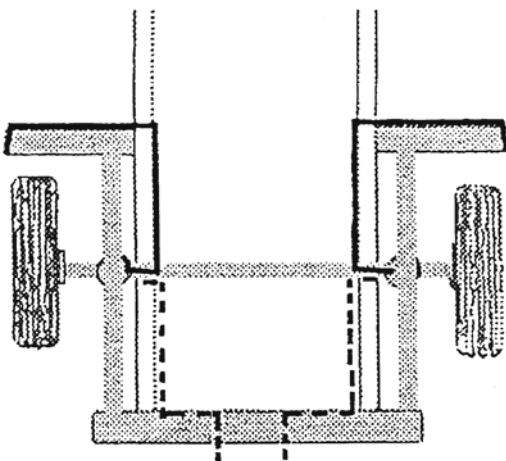

FIGURE 3

- 1 Before working on vehicle, ensure vehicle is located on safety stands and is secure.
- 2 Lower axle or raise body of vehicle until suspension is fully extended.
- 3 Coil springs may be removed or left on vehicle. During installation refer to manual if uncertain of method. Generally, lower shock absorber mounts and maybe panhard rod must be disconnected.

**CAUTION:**  
**OBSERVE TENSION ON BRAKE HOSE**  
**-DO NOT STRAIN -**

- 4 Remove bounce rubbers, from inside coil springs, if so equipped. The Polyair kit will replace (their function).
- 5 Drill 19mm (3/4") hole in centre of lower spring seat.
- 6 Select a location for the inflation valves in the rocker sills or rear floor pan ensuring that each valve will be protected and accessible with an air hose. (Figure 3).
- 7 Determine hose routing and cut adequate length of tube.

**CAUTION:**  
**LEAVE SUFFICIENT HOSE SLACK TO**  
**PREVENT ANY STRAIN ON VALVE STEM**  
**DURING NORMAL AXLE MOTIONS.**

- 8 Attach air hose to bag (Refer A, B, C Overleaf) and thread airline through centre of spacer (if supplied).
- 9 Push air bag into coil with hose / stem at bottom of coil.
- 10 Thread hose through hole in bottom spring seat then re-install coil if removed (Figure 2).

\* Early Tarago—Kit 61796 refer attached sheet for lower spring seat mod.

- A. Slide metal hose clamp onto cut tubing.
- B. Push the tube onto the stem, covering all the barbs.
- C. Slide the metal hose clamp forward until it fully covers barbed section.  
Repeat process for right side.
- D. Drill 5/16" (8.0mm) hole for inflation valves and mount as illustrated. (Rubber washer for outside weather seal.)  
Route tubing along frame to inflation valve location and cut off excess. Secure with plastic straps.
- E. Slide metal hose clamp onto tubing and push tubing onto the fitting, covering all the barbs.
- F. Slide the metal hose clamp forward until it fully covers the barbed section.

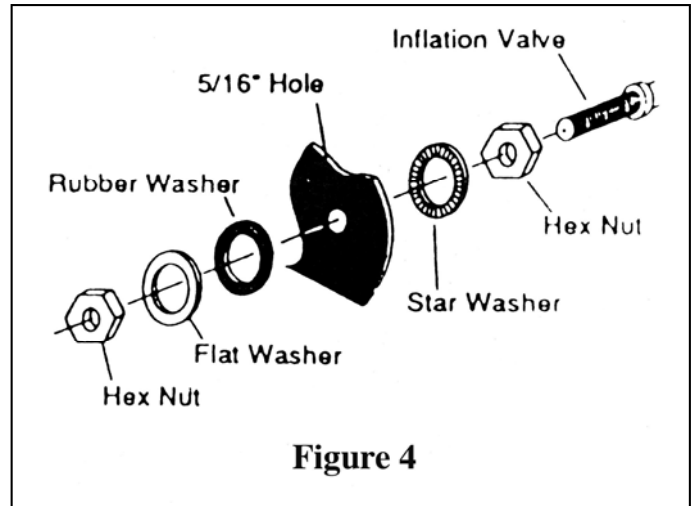

### INITIAL INFLATION PROCEDURES

**\* CAUTION •**

#### INFLATE BEFORE LOADING

TO OPERATE THE AIR SPRING UNITS, INFLATE THE CYLINDERS TO THE PRESSURE INDICATED BELOW.  
LOAD THE VEHICLE THEN DECREASE THE PRESSURE UNTIL THE VEHICLE IS LEVEL DO NOT ATTEMPT TO RAISE A LOADED VEHICLE BY INFLATING THE AIR SPRINGS IF LOADED.  
"JACK" UP BODY OF VEHICLE UNTIL LEVEL. AND THEN INFLATE TO THE DESIRED PRESSURE.

<b>MINIMUM</b>	<b>MAXIMUM</b>
<b>PRESSURE</b>	<b>PRESSURE</b>
<b>5 p.s.i.</b>	<b>30 p.s.i.</b>

**MAINTENANCE TIPS:** Always maintain at least 5 lbs (38 kpa) air pressure in the Air Springs to prevent chafing. When loading it is good practice to increase the inflation pressure of the tyres in proportion to the load being carried.



#### DO NOT INFLATE AIR CYLINDERS BEFORE READING INFLATION PROCEDURES.

- G. Raise axle or lower body until air cylinders lightly touch upper and lower spring seats.
- H. Check TAIL PIPE clearance and ensure that it is at least 3-4 inches (75-100 mm) from air cylinders. If necessary, loosen clamps and rotate or move to obtain additional clearance.
- I. Inflate cylinders to 25lbs. (170kpa) air pressure.
- J. Test for air leaks by applying a liquid soap solution to all valve cores, fittings and connections.
- K. Deflate Polyair Springs to determine best ride and handling. Sufficient air pressure must be maintained to help prevent bottoming-out.

**AN ABSOLUTE MINIMUM OF 5 psi MUST BE KEPT AT ALL TIMES.**

**CAUTION:**  
**DO NOT EXCEED VEHICLE MANUFACTURER'S GROSS VEHICLE WEIGHT RATING.**