

FIGURE 1

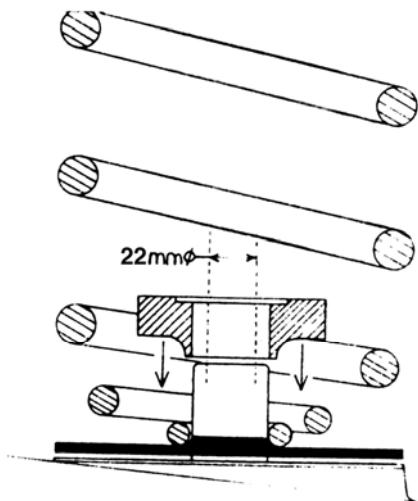

FIGURE 2

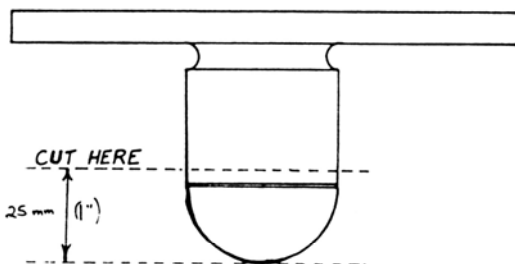

FIGURE 3

1. Before working on vehicle, ensure vehicle is located on safety stands and is secure.
2. Lower axle or raise body of vehicle until suspension is fully extended.
3. Coil springs must be removed from vehicle. Refer workshop manual if uncertain of method. Generally, lower shock absorber mounts must be disconnected.

CAUTION : OBSERVE TENSION ON BRAKE HOSE – DO NOT STRAIN

Avoid pinching of C.V. dust cover on full drop.

4. Remove top bouncer rubbers and shorten by 25mm (1”) (as per figure 3). Their function will be replaced by the Polyair Kit.
5. Drill 22 mm (7/8”) hole in centre of lower spring seat. (Break all sharp edged)

NOTE: POSITION AIR LINE CLIPS (EARS/TABS) TO REAR OF VEHICLE

6. Select a location for the inflation valves in the rocker sills or rear floor pan ensuring that each valve will be protected and accessible with an air hose.
7. Determine hose routing and cut adequate length of tube.

CAUTION: LEAVE SUFFICIENT HOSE SLACK TO PREVENT ANY STRAIN ON VALVE STEM DURING NORMAL AXLE MOTIONS.

8. Attach air hose to bag (refer A, B, C overleaf) and thread air line through centre of spacer (if supplied)
9. Push air bag into coil with hose / stem at bottom of coil.
10. Thread hose through hole in bottom spring seat then re – install coil, making certain that bottom Protector is installed (as per figure 2).

- A. Slide metal hose clamp onto cut tubing.
- B. Push the tube onto the stem, covering all the barbs.
- C. Slide the metal hose clamp forward until it fully covers barbed section.
Repeat process for right side.
- D. Drill 5/16" (8.0mm) hole for inflation valves and mount as illustrated. (Rubber washer for outside weather seal.)
Route tubing along frame to inflation valve location and cut off excess. Secure with plastic straps.
- E. Slide metal hose clamp onto tubing and push tubing onto the fitting, covering all the barbs.
- F. Slide the metal hose clamp forward until it fully covers the barbed section.

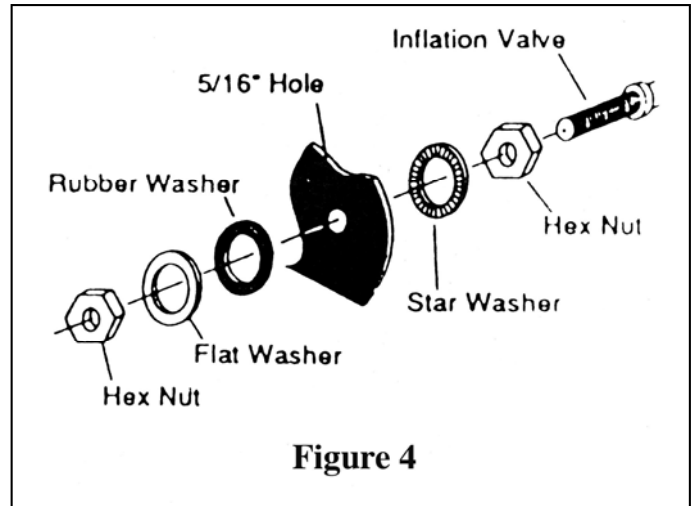

Figure 4

INITIAL INFLATION PROCEDURES

*** CAUTION •**

INFLATE BEFORE LOADING

TO OPERATE THE AIR SPRING UNITS, INFLATE THE CYLINDERS TO THE PRESSURE INDICATED BELOW.
LOAD THE VEHICLE THEN DECREASE THE PRESSURE UNTIL THE VEHICLE IS LEVEL DO NOT ATTEMPT TO RAISE A LOADED VEHICLE BY INFLATING THE AIR SPRINGS IF LOADED.
"JACK" UP BODY OF VEHICLE UNTIL LEVEL. AND THEN INFLATE TO THE DESIRED PRESSURE.

MINIMUM PRESSURE	MAXIMUM PRESSURE
5 p.s.i.	30 p.s.i.

DO NOT INFLATE AIR CYLINDERS BEFORE READING INFLATION PROCEDURES.

- G. Raise axle or lower body until air cylinders lightly touch upper and lower spring seats.
- H. Check TAIL PIPE clearance and ensure that it is at least 3-4 inches (75-100 mm) from air cylinders. If necessary, loosen clamps and rotate or move to obtain additional clearance.
- I. Inflate cylinders to 25lbs. (170kpa) air pressure.
- J. Test for air leaks by applying a liquid soap solution to all valve cores, fittings and connections.
- K. Deflate Polyair Springs to determine best ride and handling. Sufficient air pressure must be maintained to help prevent bottoming-out.

AN ABSOLUTE MINIMUM OF 5 psi MUST BE KEPT AT ALL TIMES.

**CAUTION:
DO NOT EXCEED VEHICLE
MANUFACTURER'S GROSS
VEHICLE WEIGHT RATING.**

MAINTENANCE TIPS: Always maintain at least 5 lbs (38 kpa) air pressure in the Air Springs to prevent chafing. When loading it is good practice to increase the inflation pressure of the tyres in proportion to the load being carried.

INSTRUCTIONS FOR VT – VX SEDAN AND WAGON ONWARDS & VU UTE

Top Spring Insulator

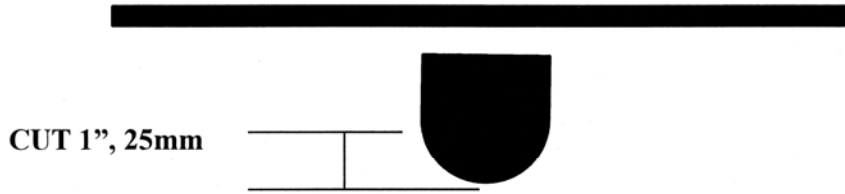

**VT – VX
ONWARDS**

**CUT 1 ½" OR
35mm AND
REMOVE**



CUT LOWER RUBBER SPRING INSULATOR AS INDICATED

DRILL 7/8", 22mm HOLE IN CENTRE OF SPIGOT

**PUSH RUBBER PROTECTOR ON SPIGOT
AFTER INSTALLATION OF COIL SPRING**

